

## Background

The design of reinforcement for concrete shells in accordance with a predetermined field of moments, as implemented in the software, is based on the provisions in DD ENV 1992-1-1 1992 Eurocode 2: Design of Concrete Structures.

Generally, slab elements are subjected to eight stress resultants. Using the software terminology, those resultants are the three membrane force components  $f_{11}$ ,  $f_{22}$  and  $f_{12}$ ; the two flexural moment components  $m_{11}$  and  $m_{22}$  and the twisting moment  $m_{12}$ ; and the two transverse shear force components  $V_{13}$  and  $V_{23}$ . For the purpose of design, the slab is conceived as comprising two outer layers centered on the mid-planes of the outer reinforcement layers and an uncracked core—this is sometimes called a "sandwich model." The covers of the sandwich model (i.e., the outer layers) are assumed to carry moments and membrane forces, while the transverse shear forces are assigned to the core, as shown in Figure 1. The design implementation in the software assumes there are no diagonal cracks in the core. In such a case, a state of pure shear develops within the core, and hence the transverse shear force at a section has no effect on the in-plane forces in the sandwich covers. Thus, no transverse reinforcement needs to be provided, and the in-plane reinforcement is not enhanced to account for transverse shear.

The following items summarize the procedure for concrete shell design, as implemented in the software:

1. As shown in Figure 1, the slab is conceived as comprising two outer layers centered on the mid-planes of the outer reinforcement layers.
2. The thickness of each layer is taken as equal to the lesser of the following:
  - Twice the cover measured to the center of the outer reinforcement.

- Twice the distance from the center of the slab to the center of outer reinforcement.

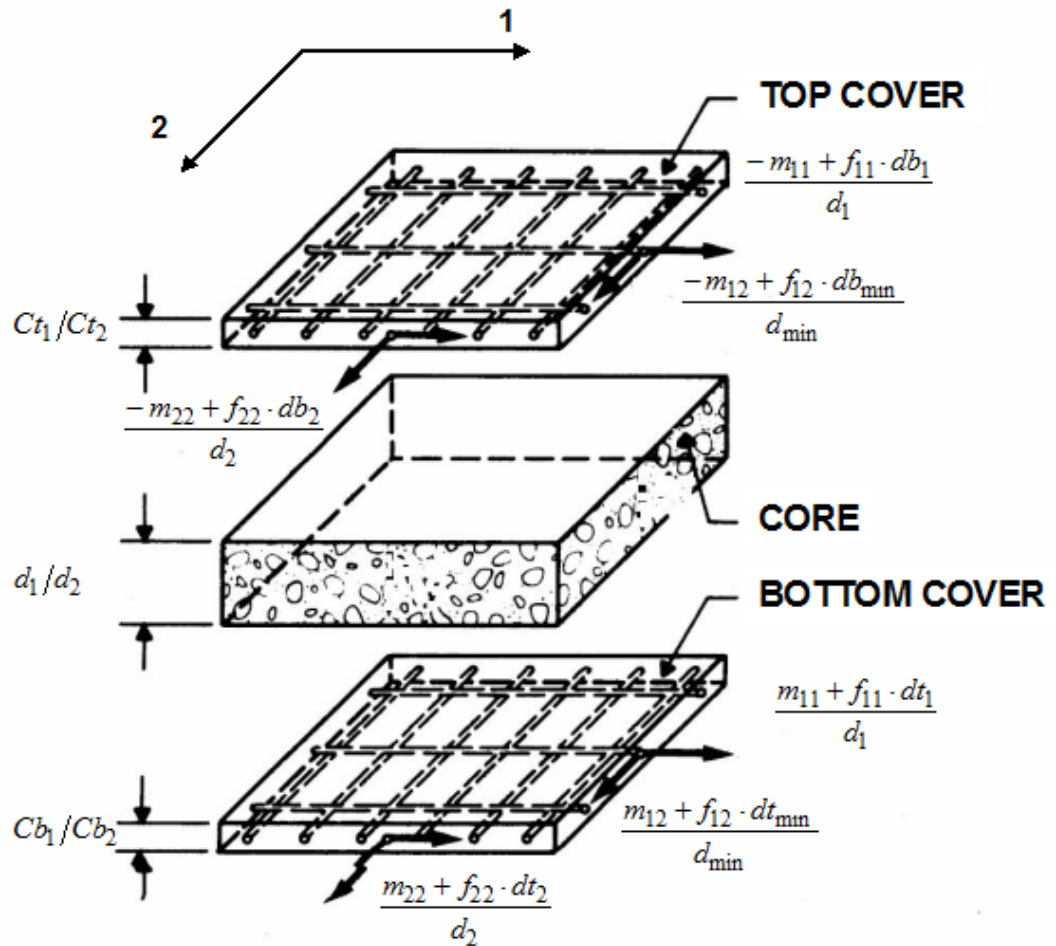

Figure 1: Statics of a Slab Element – Sandwich Model

3. The six resultants,  $f_{11}$ ,  $f_{22}$ ,  $f_{12}$ ,  $m_{11}$ ,  $m_{22}$ , and  $m_{12}$ , are resolved into pure membrane forces  $N_{11}$ ,  $N_{22}$  and  $N_{12}$ , calculated as acting respectively within the central plane of the top and bottom reinforcement layers. In transforming the moments into forces, the lever arm is taken as the distance between the outer reinforcement layers.
4. For each layer, the reinforcement forces  $NDes_1$ ,  $NDes_2$ , concrete principal compressive forces  $F_{c1}$ ,  $F_{c2}$ , and concrete principal compressive stresses  $S_{c1}$  and  $S_{c2}$ , are calculated in accordance with the rules set forth in Eurocode 2–1992.
5. Reinforcement forces are converted to reinforcement areas per unit width  $Ast_1$  and  $Ast_2$  (i.e., reinforcement intensities) using appropriate steel stress and stress reduction factors.

## Basic Equations for Transforming Stress Resultants into Equivalent Membrane Forces

For a given concrete shell element, the variables  $h$ ,  $Ct_1$ ,  $Ct_2$ ,  $Cb_1$ , and  $Cb_2$ , are constant and are expected to be defined by the user in the area section properties. If those parameters are found to be zero, a default value equal to 10 percent of the thickness,  $h$ , of the concrete shell is used for each of the variables. The following computations apply:

$$dt_1 = \frac{h}{2} - Ct_1; \quad dt_2 = \frac{h}{2} - Ct_2; \quad db_1 = \frac{h}{2} - Cb_1; \quad db_2 = \frac{h}{2} - Cb_2$$

$$d_1 = h - Ct_1 - Cb_1; \quad d_2 = h - Ct_2 - Cb_2;$$

$$d_{\min} = \text{Minimum of } d_1 \text{ and } d_2$$

$$db_{\min} = \text{Minimum of } db_1 \text{ and } db_2$$

$$dt_{\min} = \text{Minimum of } dt_1 \text{ and } dt_2$$

The six stress resultants obtained from the analysis are transformed into equivalent membrane forces using the following transformation equations:

$$N_{11}(\text{top}) = \frac{-m_{11} + f_{11} \cdot db_1}{d_1}; \quad N_{11}(\text{bot}) = \frac{m_{11} + f_{11} \cdot dt_1}{d_1}$$

$$N_{22}(\text{top}) = \frac{-m_{22} + f_{22} \cdot db_2}{d_2}; \quad N_{22}(\text{bot}) = \frac{m_{22} + f_{22} \cdot dt_2}{d_2}$$

$$N_{12}(\text{top}) = \frac{-m_{12} + f_{12} \cdot db_{\min}}{d_{\min}}; \quad N_{12}(\text{bot}) = \frac{m_{12} + f_{12} \cdot dt_{\min}}{d_{\min}}$$

## Equations for Design Forces and Corresponding Reinforcement Intensities

For each layer, the design forces in the two directions are obtained from the equivalent membrane forces using the following equations, in accordance with Eurocode 2-1992. In the equations below,  $F_{11}$ ,  $F_{22}$ ,  $F_{12}$ ,  $NDes_1$ , and  $NDes_2$  are temporary variables.

For reinforcement in top layer -

$$\text{If } N_{11}(\text{top}) \leq N_{22}(\text{top}), \text{ then } F_{11} = N_{11}(\text{top}); F_{22} = N_{22}(\text{top}); F_{12} = N_{12}(\text{top})$$

$$\text{If } N_{11}(\text{top}) > N_{22}(\text{top}), \text{ then } F_{11} = N_{22}(\text{top}); F_{22} = N_{11}(\text{top}); F_{12} = N_{12}(\text{top})$$

$$\text{If } F_{11} \geq -|F_{12}|, \text{ then}$$

$$NDes_1 = F_{11} + |F_{12}|$$

$$NDes_2 = F_{22} + |F_{12}|$$

$$Fc(\text{top}) = -2 \cdot |F_{12}|$$

If  $F_{11} < -|F_{12}|$ , then

$$NDes_1 = 0$$

$$NDes_2 = F_{22} + \frac{F_{12}^2}{|F_{11}|}$$

$$Fc(\text{top}) = -[F_{11}] \cdot \left[ 1 + \left\{ \frac{F_{12}}{F_{11}} \right\}^2 \right]$$

If  $N_{11}(\text{top}) \leq N_{22}(\text{top})$ , then  $NDes_1(\text{top}) = NDes_1$ ;  $NDes_2(\text{top}) = NDes_2$

If  $N_{11}(\text{top}) > N_{22}(\text{top})$ , then  $NDes_1(\text{top}) = NDes_2$ ;  $NDes_2(\text{top}) = NDes_1$

For reinforcement in bottom layer -

If  $N_{11}(\text{bot}) \leq N_{22}(\text{bot})$ , then  $F_{11} = N_{11}(\text{bot})$ ;  $F_{22} = N_{22}(\text{top})$ ;  $F_{12} = N_{12}(\text{bot})$

If  $N_{11}(\text{bot}) > N_{22}(\text{bot})$  then  $F_{11} = N_{22}(\text{bot})$ ;  $F_{22} = N_{11}(\text{bot})$ ;  $F_{12} = N_{12}(\text{bot})$

If  $F_{11} \geq -|F_{12}|$ , then

$$NDes_1 = F_{11} + |F_{12}|$$

$$NDes_2 = F_{22} + |F_{12}|$$

$$Fc(\text{bot}) = -2 \cdot |F_{12}|$$

If  $F_1 < -|F_{12}|$ , then

$$NDes_1 = 0$$

$$NDes_2 = F_{22} + \frac{F_{12}^2}{|F_{11}|}$$

$$F_c(\text{bot}) = -[F_{11}] \cdot \left[ 1 + \left\{ \frac{F_{12}}{F_{11}} \right\}^2 \right]$$

If  $N_{11}(\text{bot}) \leq N_{22}(\text{bot})$ , then  $NDes_1(\text{bot}) = NDes_1$ ;  $NDes_2(\text{bot}) = NDes_2$

If  $N_{11}(\text{bot}) > N_{22}(\text{bot})$ , then  $NDes_1(\text{bot}) = NDes_2$ ;  $NDes_2(\text{bot}) = NDes_1$

Following restrictions apply if  $NDes_1$  or  $NDes_2$  is less than zero:

If  $NDes_1(\text{top}) < 0$ , then  $NDes_1(\text{top}) = 0$

If  $NDes_2(\text{top}) < 0$ , then  $NDes_2(\text{top}) = 0$

If  $NDes_1(\text{bot}) < 0$ , then  $NDes_1(\text{bot}) = 0$

If  $NDes_2(\text{bot}) < 0$ , then  $NDes_2(\text{bot}) = 0$

The design forces calculated using the preceding equations are converted into reinforcement intensities (i.e., rebar area per unit width) using appropriate steel stress from the concrete material property assigned to the shell element and the stress reduction factor,  $\phi_s$ . The stress reduction factor is assumed to always be equal to 0.9. The following equations are used:

$$Ast_1(\text{top}) = \frac{NDes_1(\text{top})}{0.9(f_y)}; \quad Ast_1(\text{bot}) = \frac{NDes_1(\text{bot})}{0.9(f_y)}$$

$$Ast_2(\text{top}) = \frac{NDes_2(\text{top})}{0.9(f_y)}; \quad Ast_2(\text{bot}) = \frac{NDes_2(\text{bot})}{0.9(f_y)}$$

## Principal Compressive Forces and Stresses in Shell Elements

The principal concrete compressive forces obtained earlier are used to compute the principal compressive stresses to top and bottom layers as follows:

$$S_c (\text{top}) = \frac{F_c (\text{top})}{2 \cdot \text{Minimum}(C_{t_1}, C_{t_2})};$$

$$S_c (\text{bot}) = \frac{F_c (\text{bot})}{2 \cdot \text{Minimum}(C_{b_1}, C_{b_2})}$$

## Notations

The algorithms used in the design of reinforcement for concrete shells are expressed using the following variables:

|                     |   |
|---------------------|---|
| $Ast_1(\text{bot})$ | Reinforcement intensity required in the bottom layer in local direction 1                                   |
| $Ast_1(\text{top})$ | Reinforcement intensity required in the top layer in local direction 1                                      |
| $Ast_2(\text{bot})$ | Reinforcement intensity required in the bottom layer in local direction 2                                   |
| $Ast_2(\text{top})$ | Reinforcement intensity required in the top layer in local direction 2                                      |
| $Cb_1$              | Distance from the bottom of section to the centroid of the bottom steel parallel to direction 1             |
| $Cb_2$              | Distance from the bottom of the section to the centroid of the bottom steel parallel to direction 2         |
| $Ct_1$              | Distance from the top of the section to the centroid of the top steel parallel to direction 1               |
| $Ct_2$              | Distance from the top of the section to the centroid of the top steel parallel to direction 2               |
| $d_1$               | Lever arm for forces in direction 1   |
| $d_2$               | Lever arm for forces in direction 2   |
| $db_1$              | Distance from the centroid of the bottom steel parallel to direction 1 to the middle surface of the section |
| $db_2$              | Distance from the centroid of the bottom steel parallel to direction 2 to the middle surface of the section |
| $db_{\min}$         | Minimum of $db_1$ and $db_2$  |



|                      |  |
|----------------------|--|
| $d_{\min}$           | Minimum of $d_1$ and $d_2$   |
| $dt_1$               | Distance from the centroid of the top steel parallel to direction 1 to the middle surface of the section |
| $dt_2$               | Distance from the centroid of the top steel parallel to direction 2 to the middle surface of the section |
| $dt_{\min}$          | Minimum of $dt_1$ and $dt_2$   |
| $f_{11}$             | Membrane direct force in local direction 1   |
| $f_{12}$             | Membrane in-plane shear forces   |
| $f_{22}$             | Membrane direct force in local direction 2   |
| $Fc(\text{bot})$     | Principal compressive force in the bottom layer  |
| $Fc(\text{top})$     | Principal compressive force in the top layer   |
| $f_y$                | Yield stress for the reinforcement   |
| $h$                  | Thickness of the concrete shell element  |
| $m_{11}$             | Plate bending moment in local direction 1  |
| $m_{12}$             | Plate twisting moment  |
| $m_{22}$             | Plate bending moment in local direction 2  |
| $N_{11}(\text{bot})$ | Equivalent membrane force in the bottom layer in local direction 1                                       |
| $N_{11}(\text{top})$ | Equivalent membrane force in the top layer in local direction 1  |
| $N_{12}(\text{bot})$ | Equivalent in-plane shear in the bottom layer  |
| $N_{12}(\text{top})$ | Equivalent in-plane shear in the top layer   |
| $N_{22}(\text{bot})$ | Equivalent membrane force in the bottom layer in local direction 2                                       |
| $N_{22}(\text{top})$ | Equivalent membrane force in the top layer in local direction 2  |

---

|                         |   |
|-------------------------|---|
| $ND_{es_1}(\text{top})$ | Design force in the top layer in local direction 1    |
| $ND_{es_2}(\text{top})$ | Design force in the top layer in local direction 2    |
| $ND_{es_1}(\text{bot})$ | Design force in the bottom layer in local direction 1 |
| $ND_{es_2}(\text{bot})$ | Design force in the bottom layer in local direction 2 |
| $Sc(\text{bot})$        | Principal compressive stress in the bottom layer      |
| $Sc(\text{top})$        | Principal compressive stress in the top layer         |
| $\phi_s$                | Stress reduction factor                               |

## References

- DD ENV 1992-1-1: 1992 – Eurocode 2: Design of Concrete Structures, Part 1.  
General rules and rules for buildings